

Installation Instructions

For set # 8.3130

2013 Scion FR-S

Rear Control Arm Bushings

© 2012 Energy Suspension. All rights reserved.
 May not be reproduced, in any form, or by any means,
 without the written consent of Energy Suspension.

It is recommended that if you are unfamiliar with this type of work that you refer to a qualified service center specializing in this type of work. It is also recommended that if you choose to do this work yourself that a factory service manual be obtained for the proper procedures pertaining to removal, replacement and proper torque specifications for your vehicle. This instruction set is intended as a guideline for the safe installation of Energy Suspension's polyurethane bushings, once you have removed the factory components from your vehicle. Wheel alignment is almost always disturbed when suspension components are removed or replaced. It is recommended that you have the alignment checked on your vehicle at a qualified alignment shop. Energy Suspension recommends that you read over all the installation instructions and check all P/N's and quantities in the parts list before you start. Call customer service at 949-361-3935 if the parts in your kit do not match this parts list. Prior to installation, make sure that your car is in excellent mechanical condition and that there are no suspension or steering related problems. This part has been designed to work only with a car that is in good state of repair. No matter how carefully we design our parts, this is one area we have no control over and cannot be held responsible.

Parts list:

- 4 - 2915 (Upper control arm bushing frt. pos.)
- 2 - 15.10.335.39 (.875" x .500" x 1.943" sleeve)
- 4 - 2916 (Upper control arm bushing rr. pos.)
- 2 - 15.10.472.39 (.875" x .500" x 2.355" sleeve)
- 4 - 2917 (Lower control arm bushing at sub-frame)
- 2 - 15.10.437.39 (.875" x .500" x 1.650" sleeve)
- 4 - 2913 (Lower control arm bushing at knuckle)
- 2 - 15.10.245.39 (.750" x .480" x 1.960" sleeve)
- 4 - 2919 (Lower trailing arm bushing at sub-frame)
- 2 - 15.10.497.39 (.875" x .500" x 1.880" sleeve)
- 4 - 2912 (Lower trailing arm bushing at knuckle)
- 2 - 15.10.497.39 (.875" x .500" x 1.880" sleeve)
- 4 - 2918 (Lower toe adj. control arm bushing)
- 2 - 15.10.673.39 (1.000" x .563" x 1.650" sleeve)
- 2 - 9.11107 (grease)

Torque values:

- Upper arm flange bolts (66 lbf·ft)
 - Upper ball joint retaining flange bolt (59 lbf·ft)
 - Hub and bearing retaining bolts (48 lbf·ft)
 - Parking brake hose mounting bolt (13 lbf·ft)
 - Speed sensor mounting bolt (5.5 lbf·ft)
 - Caliper bracket mounting bolts (49 lbf·ft)
 - Shock absorber with coil spring flange bolt at control arm (59 lbf·ft)
 - Stabilizer end link flange bolt at control arm (28 lbf·ft)
 - Lower control arm flange bolt at sub-frame and knuckle (59 lbf·ft)
 - Lower trailing arm flange bolt at sub-frame and knuckle (81 lbf·ft)
 - Lower toe adj. control arm flange bolt at sub-frame (74 lbf·ft)
 - Lower toe adj. control arm ball joint nut (44 lbf·ft)
- Note:** Tighten castle nuts to lower torque spec, then tighten only far enough to align slot with pin hole. Always install new cotter pins.

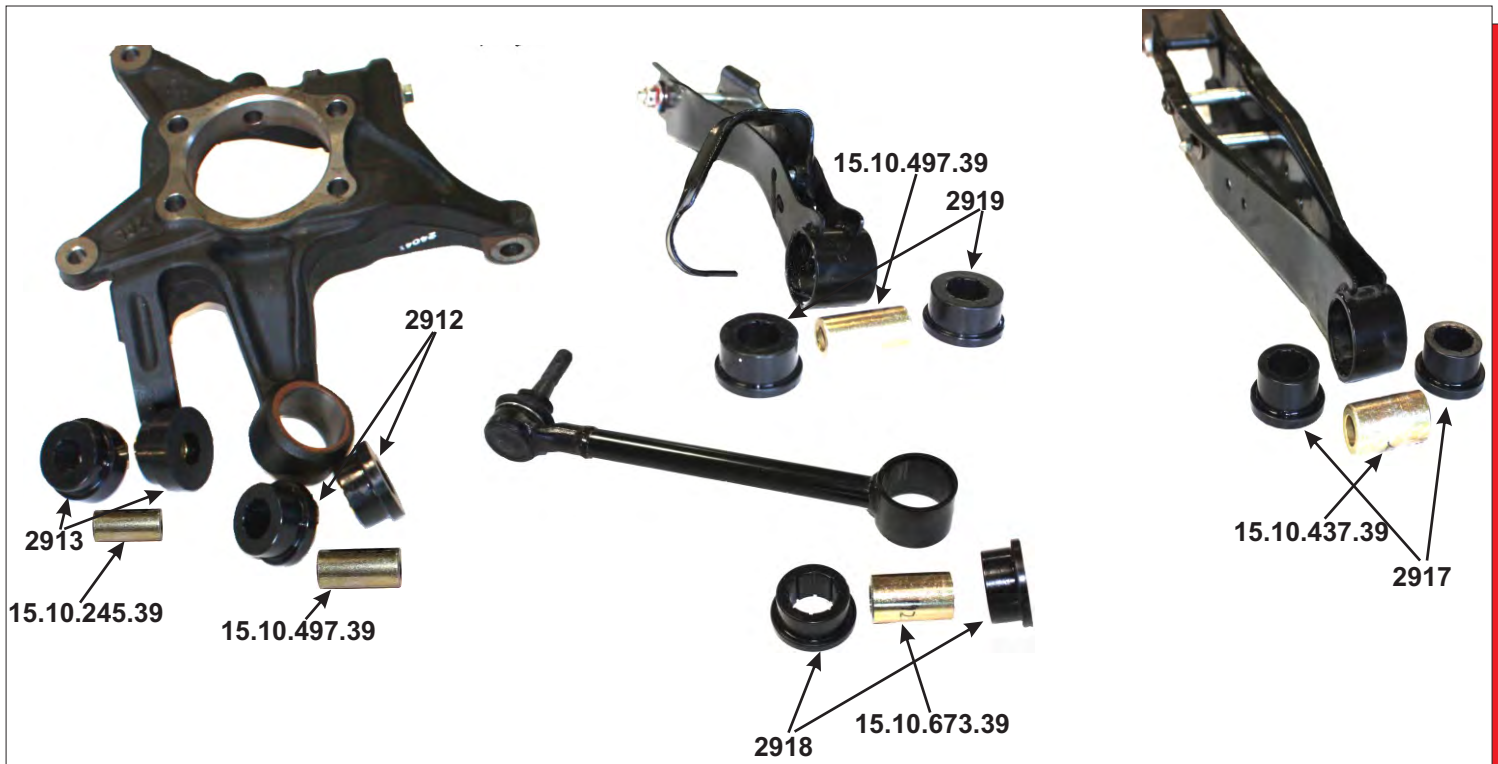

Lower Control Arms: The O.E. shell and bushing must be removed from all lower control arms before new polyurethane bushings can be installed. Use a hydraulic press to apply enough pressure to remove the shell while still supporting the arm. You will need metal tubing with an O.D. smaller than the I.D. of the arm eyelet in order to press out the O.E. bushing and another piece of tubing with an I.D. slightly larger than the I.D. of the arm eyelet to support the arm (Pic 1). If a hydraulic press not available use a threaded rod along with a series of tubing and washers (Pic 2*). Tighten the nuts at either end of the threaded rod to apply a force on the opposing Tubing #1 and Tubing #2 until bushing and shell are removed. Refer to the chart below for the appropriate size tubing to remove each bushing and shell. Observe all safety precautions while operating the hydraulic press, as worn and/or damaged bushing may react hazardously under pressure.

Location	Tubing #1 O.D.	Tubing #2 I.D.
Lower Control Arm @ sub-frame	1.320"-1.240"	1.350"-1.500"
Lower Control Arm @ knuckle	1.550"-1.450"	1.575"-1.640"
Lower Trailing Arm @ sub-frame	1.525"-1.450"	1.600"-1.750"
Lower Trailing Arm @ knuckle	1.525"-1.450"	1.600"-2.000"
Lower Toe Adj. Arm @ sub-frame	1.450"-1.375"	1.500"-1.750"

Remove all burrs and sharp edges from control arm eyelets before installing new polyurethane bushings. Be sure to grease all sides of the new bushings that will contact any metal parts during operation.

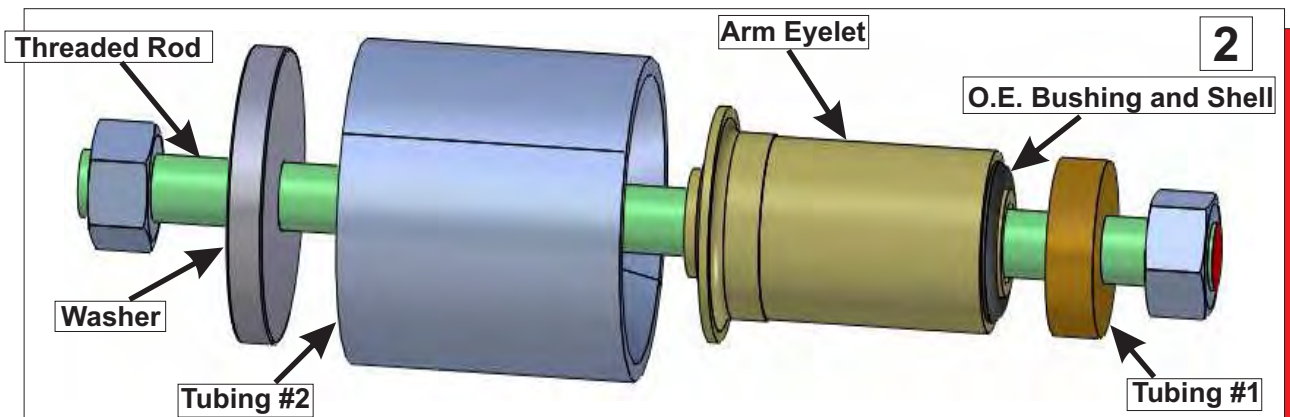
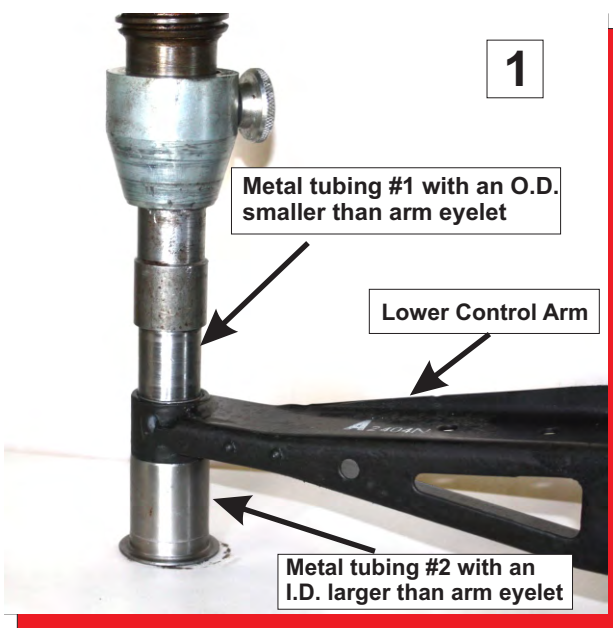

*This picture is for universal applications and should be used only as a reference. Actual O.E. parts and hardware may look different than representation.

Upper Control Arm: The front position O.E. bushing and shell can be removed using a hydraulic press or threaded rod, just as you did for the lower control arms (Pic 1). The rear position eyelet uses a two piece O.E. bushing and shell. A chisel or pry bar must be used to remove one side of this bushing. Carefully wedge the chisel or pry bar in between the control arm and inner metal flange of the bushing, being sure not to damage the arm eyelet (Pic 2). Slowly pry the bushing and shell along the O.D. and away from the arm until one side is removed. The bushing and shell on the remaining side can be pried off just as the first side was or can be pressed out by applying pressure from inside the control arm eyelet. Remove all burrs and sharp edges from the control arm eyelet. Apply grease to all sides of the new polyurethane bushings that will contact any metal parts during operation.

